

**A NEW VIEW OF
THERMODYNAMICS
RELATING TO
THE WORKING
CAPABILITY OF
PRESSURIZED
FLUIDS**

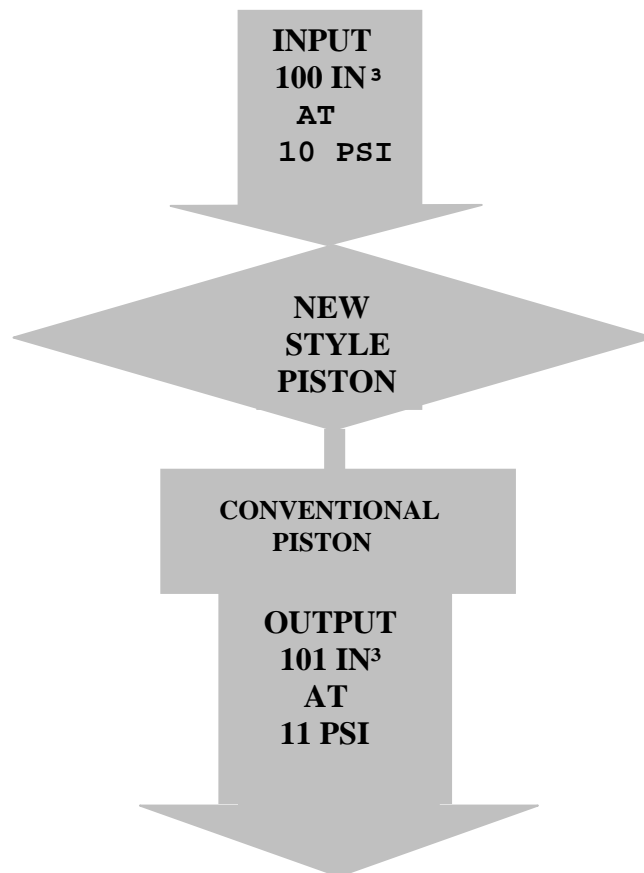

TYPICAL CYCLE

CONTACT:

David Strain

(905) 640-2333

EMAIL: analystsofpneumatic@bellnet.ca

WEB: <http://www.apscontrols.ca>

CONTENTS

SECTION ONE 1.0 REPORT OVERVIEW

1.1 Information regarding patents and layout of report. 1

SECTION TWO 2.0 FIRST EXPLANATION RELATING TO THE LAWS OF THERMODYNAMICS

2.1 Description as the fundamental science relates to pressurized fluids. 2

2.2 Drawing illustrating the efficiency difference comparing a diamond-shaped actuator to a conventional actuator. 3

2.3 Drawing illustrating the means of extracting the differential in work potential. 4

SECTION THREE 3.0 SECOND EXPLANATION RELATING TO THE LAWS OF THERMODYNAMICS

3.1 Description of fluid power in conventional applications. 5

3.2 Description of impact the diamond-shaped actuator has on fluid efficiency. 6

3.3 Drawings relating to conventional fluid efficiency. 7

3.4 Drawing comparing efficiencies of conventional actuators to diamond-shaped actuators. 8

SECTION FOUR 4.0 ILLUSTRATES MECHANICAL AND ELECTRICAL ASPECTS OF INVENTION.

4.1 Illustrates driving cycle of invention. 9

4.2 Illustrates first recharge cycle of invention. 10

4.3 Illustrates second recharge cycle of invention. 11

SECTION 5.0 ADDRESSES PRESSURE/POWER RELATIONSHIP OF INVENTION.

5.1 Graph illustrating that the system's static pressure determines the power output of the invention. 12

SECTION 6.0 ADDRESSES VOLUME CHANGE RELATIONSHIP COMPARING A DIAMOND-SHAPED ACTUATOR TO A CONVENTIONAL ACTUATOR FOR IDENTICAL TRAVEL.

6.1 Chart illustrating the non linear volume change of a diamond-shaped actuator relative to the linear volume change of a conventional actuator for equal travels. 13

This report contains an ***extended viewpoint*** regarding the Laws of Thermodynamics, concerning the working potential of pressurized fluids.

The newly developed Hydraulic Motor is based on concepts contained within our patent application. ***The USA patent was issued on August 31, 2004, patent number 6,782,800. The European patent has been granted under number 1240435. The patents have been granted in Switzerland, Belgium, France, Italy, the UK and Ireland under patent number 1240435. The patent has been granted in Germany under patent number DE 600 15 181 T2 2005.11.24. The patent has been granted in Austria under patent number AT E 280 331 T1.*** The whole principle is based on squaring off a conventional piston, hinging the walls and rotating it by 45°.

This report contains two different approaches to explain the new discovery relative to the currently accepted Laws of Thermodynamics.

- (1) The first explanation is contained in pages 2, 3 and 4.
- (2) The second explanation is contained in pages 5, 6, 7 and 8.

Pages 9,10 and 11 are control system drawings that illustrate the operation of the hydraulic motor in its three modes of operation.

Page 12 is a graph created from data extracted, with a computerized system, directly from an actual hydraulic motor when it was running. This graph illustrates that the system pressure determines the power generation of the hydraulic motor.

Page 13 is a graph that illustrates the relationship of volume change for a conventional piston relative to a diamond shaped piston for the same linear travel, when the boundary face of the conventional piston is the same area as each wall of the diamond shaped piston.

Prepared by Dave Strain (905) 640-2333

QUASIEQUILIBRIUM EXPANSION OR COMPRESSION PROCESS

The figure 2.4, below, is copied from section 2.2.3 in the Second Edition of "FUNDAMENTALS OF ENGINEERING THERMODYNAMICS" written by MICHAEL J. MORAN of Ohio State University and HOWARD N. SHAPIRO of Iowa State University and Technology.

A thorough understanding of this segment in the Laws of Thermodynamics is required for one to understand the development of the hydraulic displacement motor.

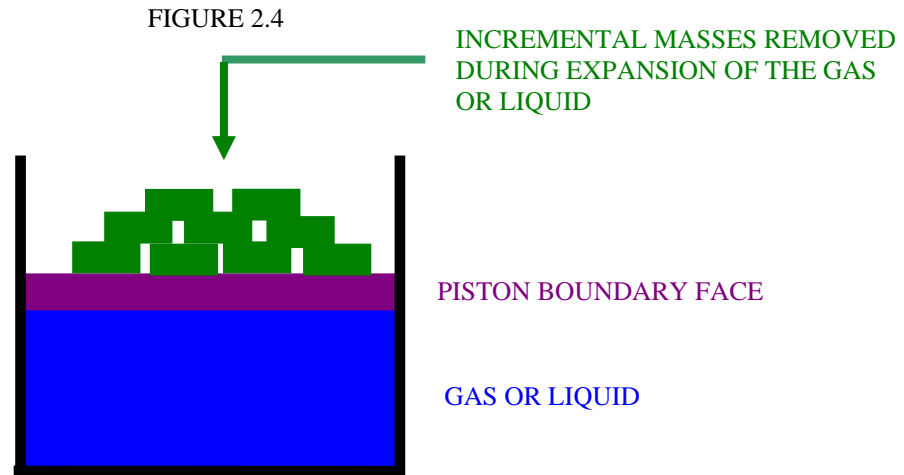

The Laws of Thermodynamics conclude that the upward force generated by applying pressurized fluid over the piston's moving boundary face is equal to the downward force exerted by the lifted mass when the piston is in a state of equilibrium. I completely agree with this conclusion for a conventional piston as illustrated.

This paper uses pressures and areas identical to our model to establish an understanding of why our new type of piston attains a power increase over a conventional piston.

When the face area of the conventional piston is 23.95 in² and the pressure is 2.51 PSI, the upward force is 60 pounds. If the piston is at equilibrium, the downward force of the mass is 60 pounds.

The piston illustrated in Figure 2.4 has linear characteristics regarding its travel to volume relationship. For 2.5 inches of travel, with a face area of 23.95 in², 59.875 in³ of volume change is required to lift the 60 pounds of mass.

If you rotate a squared off piston 45° and hinge its walls, as per our model, you will create a new type of piston that expands in a diamond shape. **It will have four moving walls and exert its total force at the tip.** It will only require 59.318 in³ of fluid to lift the same 2.5 inches. This is .9% less fluid to travel the same distance. The relationship of travel to volume is *not* linear for this new piston.

The experiments with our model have demonstrated that the diamond shaped piston requires 2.24 PSI to lift the 60 pounds of mass to an elevation of 2.5 inches. This is 10.7% less pressure to do the same amount of work as the piston in the illustration 2.4 in "FUNDAMENTALS OF ENGINEERING THERMODYNAMICS"

In comparison to the illustration 2.4 in "FUNDAMENTALS OF ENGINEERING THERMODYNAMICS", the diamond shaped piston can achieve the same work with **.9% less fluid volume** and with **10.7% less pressure.**

This allows the diamond shaped piston to displace fluid out of a conventional piston, at greater volume and at greater pressure, than the volume of fluid required to initially drive the diamond shaped piston.

A model, that actually functions, has been built using this relationship to demonstrate a reciprocating motor that powers itself and generates surplus energy.

AN EXTENDED VIEW OF THE LAWS OF THERMODYNAMICS RELATING TO THE QUASIEQUILIBRIUM EXPANSION OR COMPRESSION PROCESSES

NORMALLY ACCEPTED RELATIONSHIP OF PRESSURIZED FLUID AND WORK.

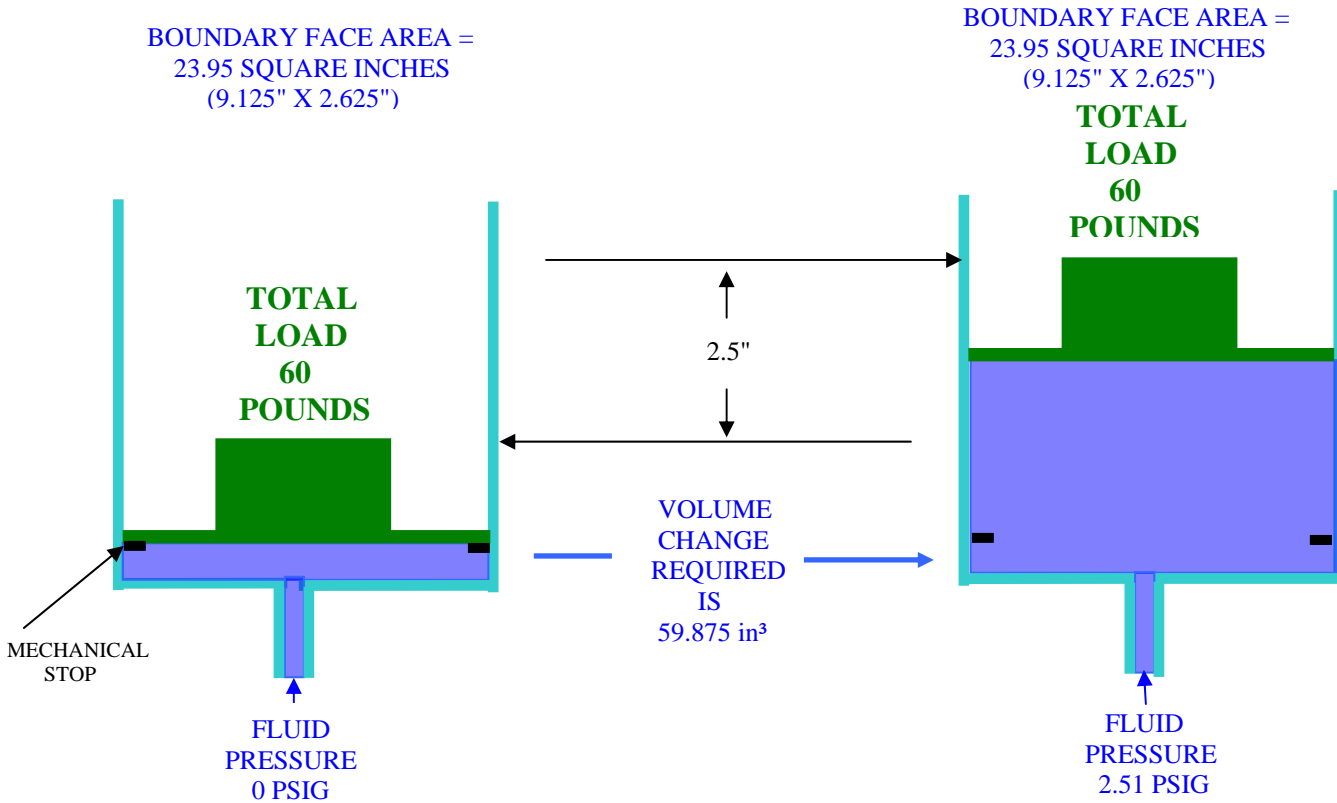

A NEW VIEW POINT

INCREASED WORK CAPABILITY OF FLUID BY ROTATING PISTON 45°.

(FIGURES USED REFLECT ACTUAL EXPERIMENTAL RESULTS)

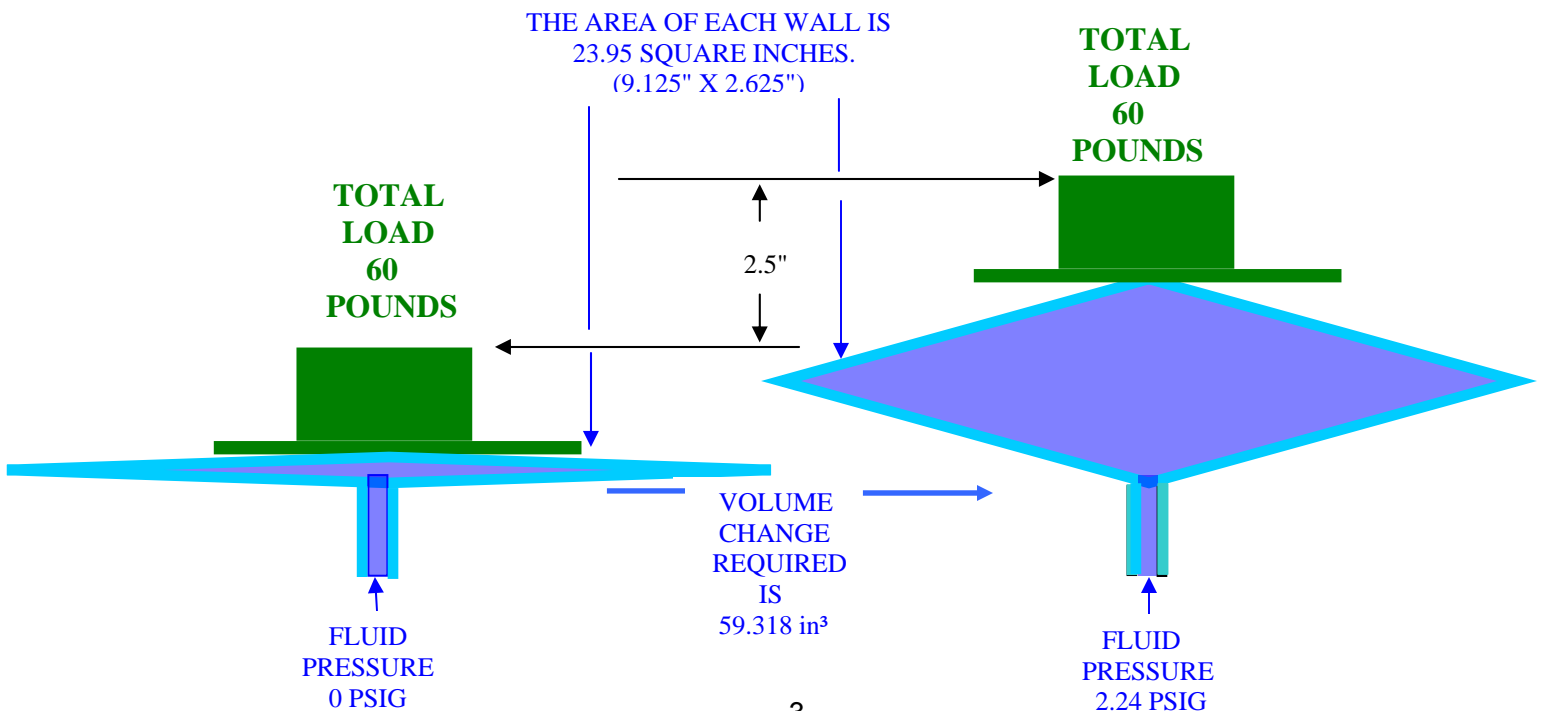

EXAMPLE OF HOW POWER GAIN IS ACHIEVED.

- AT PISTON #1, CLOSE VALVE "B" AND OPEN VALVE "A" TO FILL PISTON #1 FROM A FLUID SOURCE UNTIL THE 60# LOAD HAS LIFTED 2.5".
- CONNECT PISTON #1 TO PISTON #2 AS SHOWN. CLOSE VALVE "A"; THEN OPEN VALVE "B".
- THE 60# LOAD ON PISTON #1 WILL FORCE THE FLUID FROM PISTON #1 INTO PISTON #2, LIFTING THE 66# LOAD OF PISTON #2, 2.5", WHILE USING ONLY 99% OF THE FLUID AVAILABLE IN PISTON #1.
- THE FORCE DEVELOPMENT AVAILABLE AT THE TIP OF PISTON #2, VIA THE FLUID FLOWING FROM PISTON #1 INTO PISTON #2, IS MORE THAN 10% GREATER THAN REQUIRED TO LIFT THE 60# LOAD ON PISTON #1.
- THE 66# LOAD LIFTED BY PISTON #2 CAN BE RE-APPLIED TO PISTON #1 TO DISPLACE A GREATER VOLUME AT A GREATER PRESSURE ON THE NEXT CYCLE.

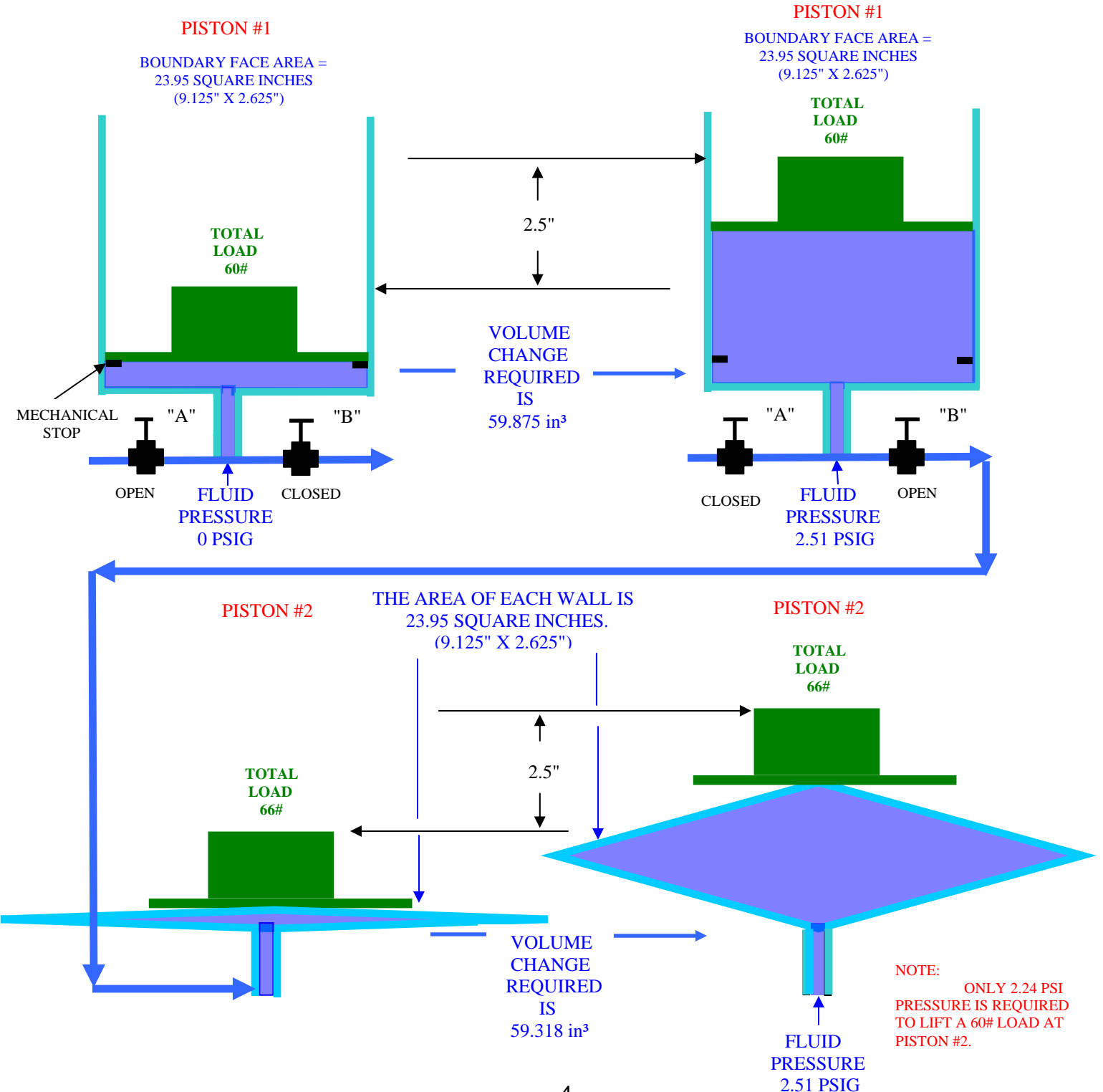

HYDRAULIC MOTOR EXPLANATION

GENERALLY ACCEPTED CONDITIONS

The accepted **Laws of Thermodynamics** describe the working capability of pressurized fluid. This is addressed in the text, "**Fundamentals of Engineering Thermodynamics**", written by Shapiro and Moran; section 2.2.3, "**Work in Quasiequilibrium Expansion or Compression Processes**".

The Laws of Thermodynamics establish that a piston will move in the direction of lesser force until the forces on both sides of the piston are equal. If the force is reduced on one side, the piston movement will continue until equilibrium has been regained.

Shapiro and Moran used a conventional piston, with incremental masses as a load to illustrate this fact. (FIGURE 1) (Page 7)

A piston with a ten square inch boundary face and a fluid pressure of 10 PSIG would reach equilibrium if the mass it was lifting weighed one hundred pounds.

The potential work in the lifted mass has a linear relationship to the work required to put the pressurized fluid into the piston "B" and they are equal at all times equilibrium has been reached.

The same fact can be demonstrated by linking the drive rods of two identical pistons. (FIGURE 2) (Page 7) If both pistons have the same pressure applied to them the force of each piston would be equal and there would be no movement. If either piston's pressure were reduced, the piston with the higher pressure would attain a force advantage and start to push back the other piston. If the pressures become equal at some point, the movement will stop because the forces on the pistons will have become equal; therefore, the system will have regained equilibrium.

At mid-point of the pistons' stroke, the amount of work to provide the pressurized fluid to both pistons is equal and the work relationship potential is linear.

EXAMPLE:

Consider both pistons to have a rectangular drive face of one inch by ten inches and a maximum stroke of ten inches.

When 10 PSIG pressure is applied to the pistons, they would both exert a force of one hundred pounds.

Equilibrium, at the middle of their strokes, would require the same volume of fluid applied to each piston.

Consider the pistons arranged as in FIGURE 3 (Page 8). Piston "A" is filled with fluid and connected to a cushion tank "C" that is able to accept piston "A's" volume at a constant pressure of 10 PSIG.

Piston "B" receives fluid from another source.

When piston "B" receives fluid pressurized to about 10.01 PSIG it will start to displace piston "A's" fluid into cushion tank "C".

In this case the volume required driving piston "B" is the same as the volume displaced in piston "A". The pressure of the fluid in piston "B" is very slightly higher than the pressure of the fluid displaced from piston "A".

The work potential relationship of the two fluid volumes is linear.

NEW CONSIDERATIONS

The accepted facts from the Laws of Thermodynamics in the previous part of this paper are the basic building blocks to understand the operation of the hydraulic motor. There is one significant alteration to the arrangement of piston "B". It is rotated forty-five degrees, hinged at its walls and anchored at two points to make a different piston, "B2", as in **FIGURE 4 (Page 8)**.

This arrangement allows piston "B2" to expand in a diamond shaped form with piston "B2's" external force, *the total of four moving walls*, culminating at the tip connected to piston "A".

The face area of each of piston "B2's" walls is equal to the boundary face of piston "A". This relationship assures that when piston "B2" expands to displace the fluid in piston "A", the amount of fluid required to cause movement in piston "B2" will always be less than the volume of fluid displaced from piston "A".

The volume displacement relationship of piston "A" and piston "B2" is NOT linear.

This relationship allows a lesser volume of fluid to displace a greater volume of fluid for the same linear travel.

The larger volume of displaced fluid in piston "A" has to attain a pressure equal to or greater than the pressure of the fluid in piston "B2" in order for the hydraulic motor to function. This is achieved, as the force at the tip of piston "B2" is greater than the force applied to any one of piston "B2's" four equal walls. The boundary area of piston "A" is equal to each wall of piston "B2".

Our experiments indicate that there is a force advantage from zero degree expansion to about twenty-two degree expansion. The power gain starts in the range of fifteen to twenty percent and decreases to zero percent at about twenty-two degree rotation.

The net result of these considerations is that a smaller volume of fluid at a lesser pressure can displace a larger volume of fluid at a higher pressure.

A circuit has been developed, using this fact, to build a machine that runs itself with no energy input other than the initial start. The machine can be opposed to extract a percentage of the surplus power generated in each cycle while the machine continues to run.

FIGURE 1

STATE OF
EQUILIBRIUM

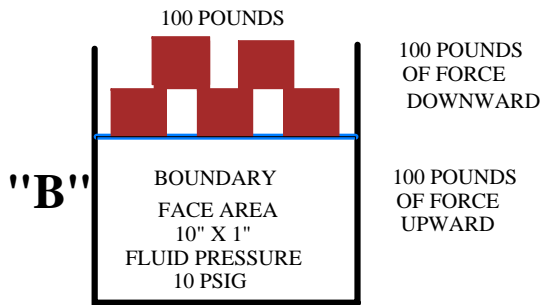

ILLUSTRATION SIMILAR
TO FIGURE 2.4, PAGE 34
IN "FUNDAMENTALS OF
ENGINEERING THERMODYNAMICS"
WRITTEN BY MORAN & SHAPIRO

FIGURE 2

STATE OF
EQUILIBRIUM

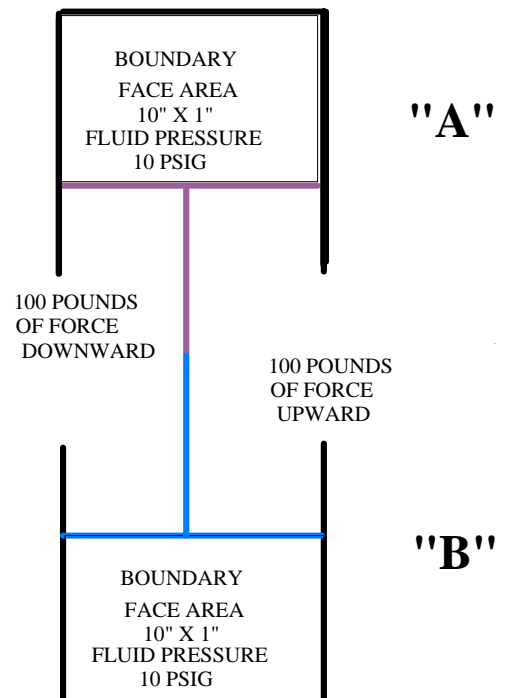

FIGURE 3

FLUID BEING FORCED INTO PISTON "B"
DISPLACES AN EQUAL AMOUNT OUT OF PISTON "A"
INTO CUSHION TANK "C"
NOTE: THE PRESSURE IN PISTON "B" IS HIGHER
THAN THE PRESSURE IN PISTON "A"

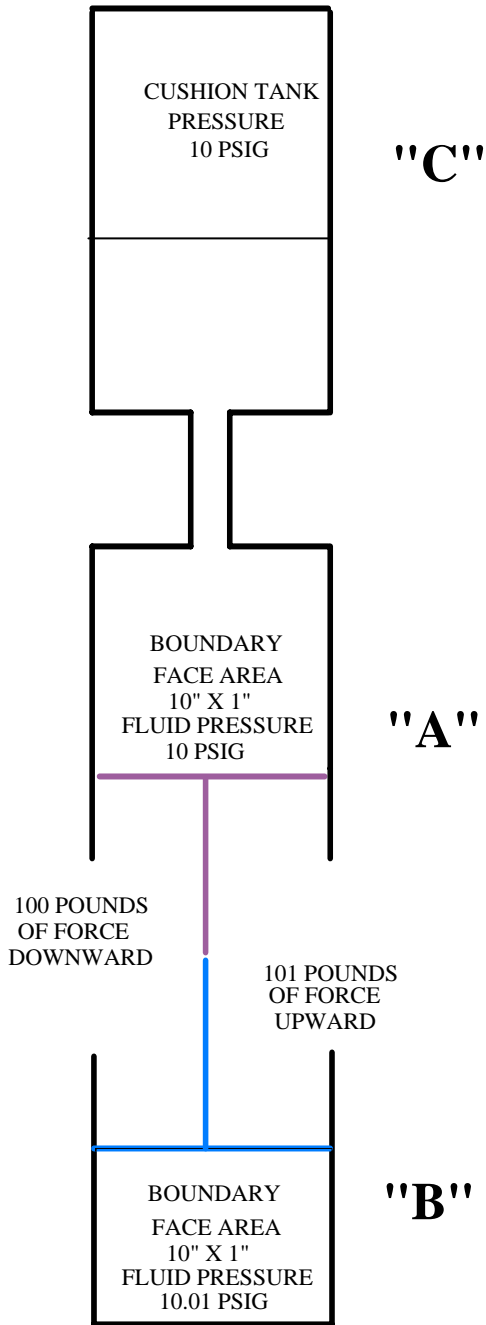
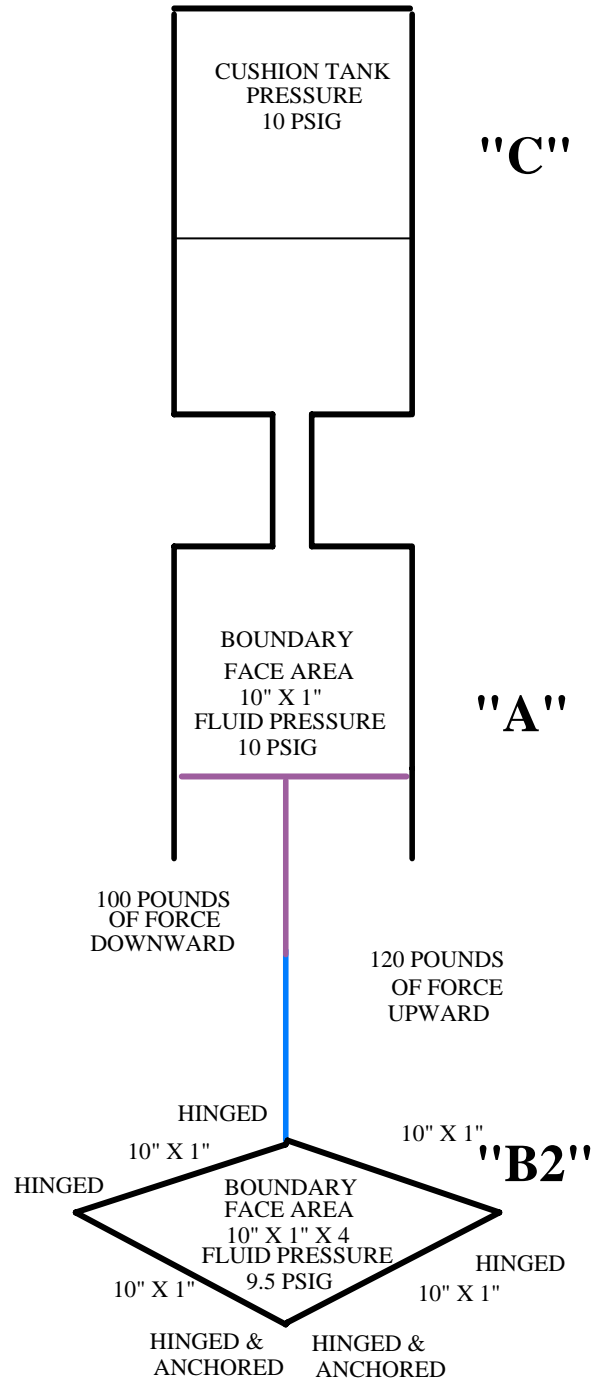
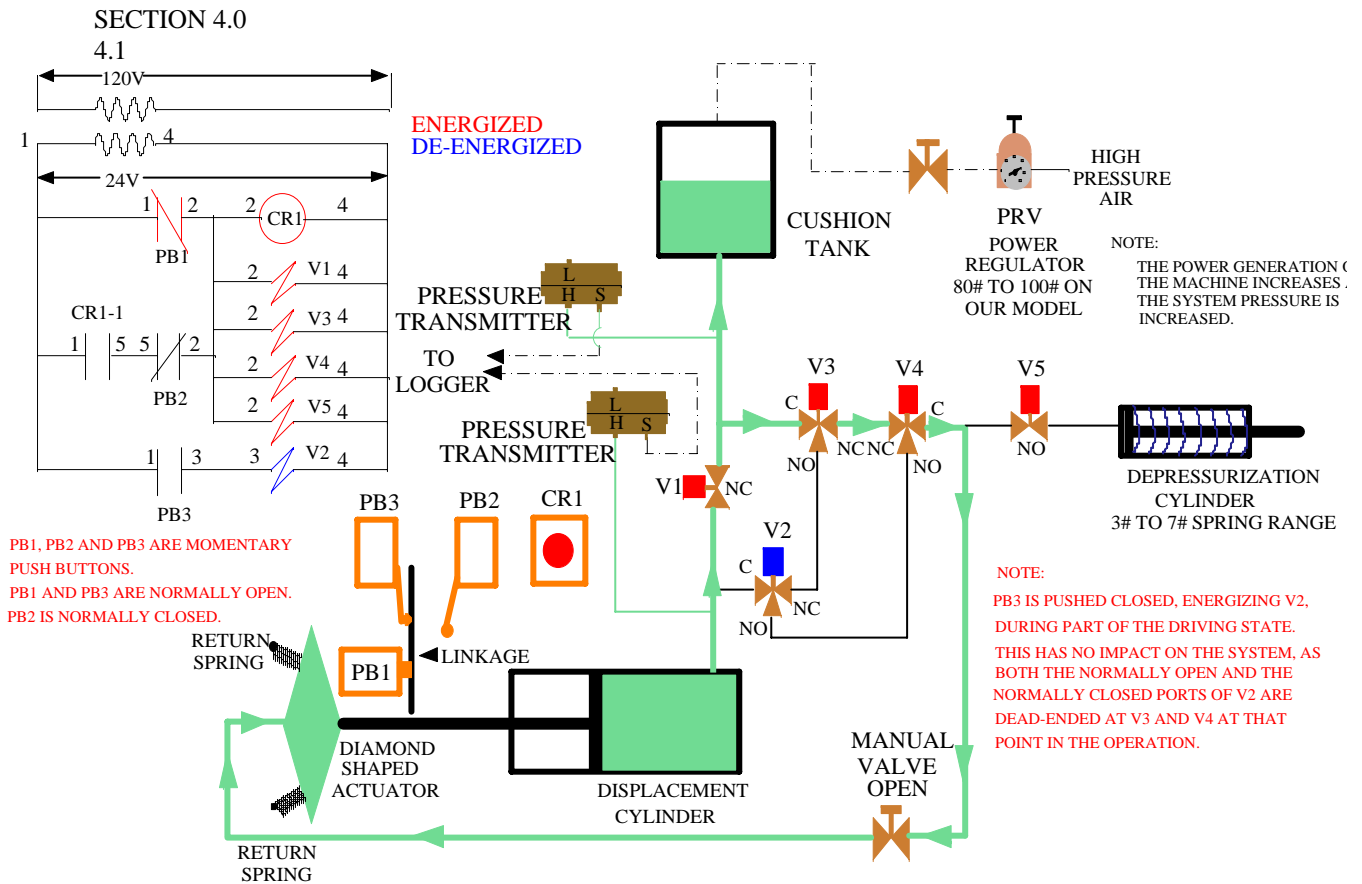

FIGURE 4

FLUID BEING FORCED INTO PISTON "B2"
DISPLACES A GREATER AMOUNT OUT OF PISTON "A"
INTO CUSHION TANK "C".
NOTE: THE PRESSURE IN PISTON "B2" IS LESS TH
THE PRESSURE IN PISTON "A"





DRIVING STATE

The driving state is started when the linkage forces push button (PB1) closed to energize V1, V3, V4, V5 and CR1. The contact of CR1 closes to lock power on these devices when PB1 re-opens as the drive movement starts.

When V1, V3, V4, and V5 are energized the flow pattern is as illustrated on this drawing.

The diamond shaped actuator, the displacement cylinder and the cushion tank experience the same pressure.

The diamond shaped actuator develops about 10% to 15% greater total force at its tip than the counter force developed in the displacement cylinder.

Each of the four faces of the diamond shaped actuator have the same area as the displacement cylinder's boundary face. This causes more fluid to be driven out of the displacement cylinder than is required to drive the diamond shaped actuator for the same linear travel.

About 99% of the fluid driven out of the displacement cylinder flows to the diamond shaped actuator and about 1% of the fluid flows into the cushion tank.

The differential in force between the diamond shaped actuator and the displacement cylinder may be used to drive any mechanical device external to this machine, such as a generator or pump.

When the linkage forces push button (PB2) open V1, V3, V4, V5 and CR1 are de-energized which causes the driving state to stop.

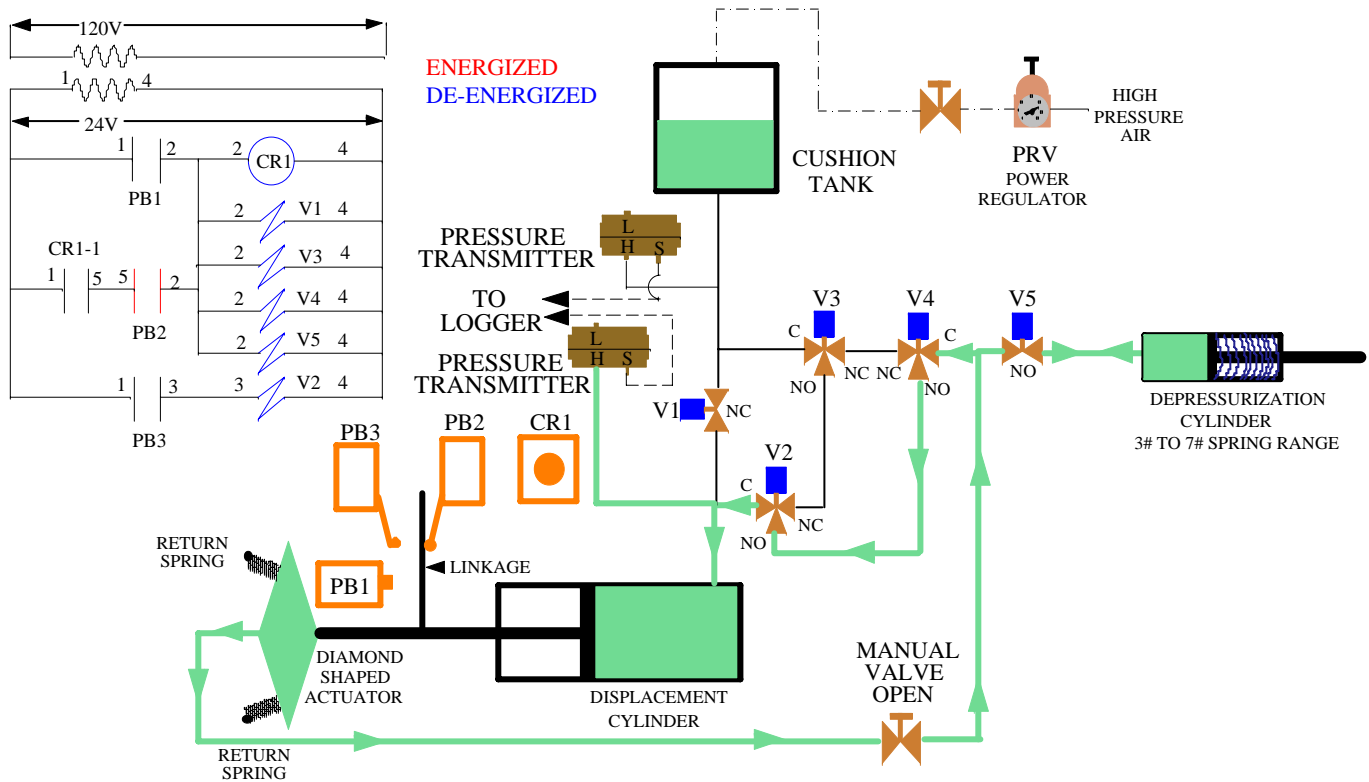

FIRST RECHARGE CYCLE

The linkage pushes PB2 open, which causes V1, V3, V4, V5 and CR1 to de-energize and the flow pattern illustrated on this drawing is established.

The pressurized cushion tank is isolated.

The diamond shaped actuator, the displacement cylinder and the depressurization cylinder all experience a common pressure.

The depressurization cylinder strokes, which de-pressurizes all three components. This removes the diamond shaped actuator's power advantage over the return springs. The return springs retract to force the fluid in the diamond shaped actuator back into the displacement cylinder.

When the common pressure drops below the spring range of the depressurization cylinder, the fluid is forced into the displacement cylinder from the depressurization cylinder.

When the 99% of the fluid that came out of the displacement cylinder has been returned to the displacement cylinder, the linkage forces push button (PB3) to close which energizes V2.

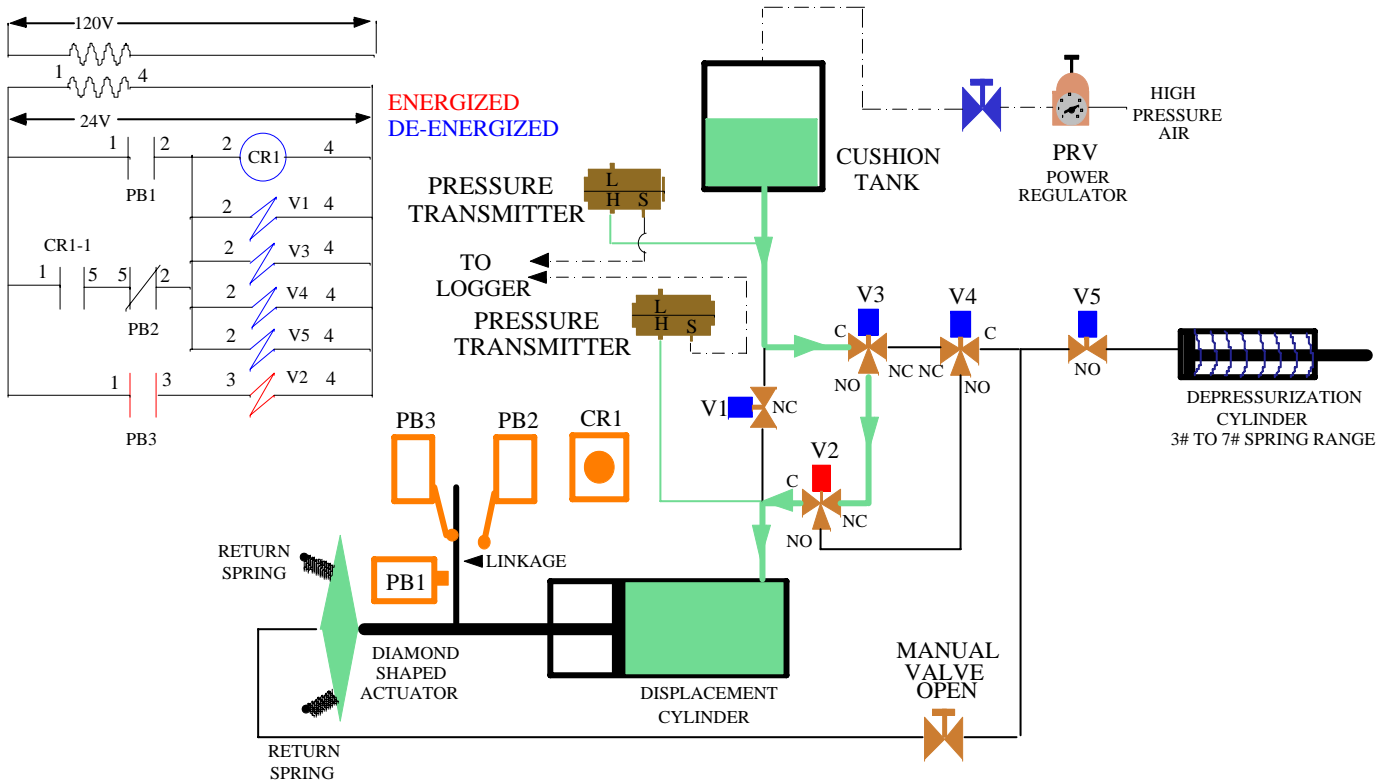

SECOND RECHARGE CYCLE

The linkage pushes PB3 closed to energize V2. This establishes the flow pattern illustrated on this drawing.

The 1% of the fluid that was forced from the displacement cylinder into the cushion tank is forced back into the displacement cylinder from the cushion tank.

When the displacement cylinder is completely refilled, the linkage of the displacement cylinder pushes PB1 closed and the cycle repeats.

NOTE: The linkage is not mechanically connected to the diamond shaped actuator; therefore, there will be a temporary gap between them during the second recharging stage.

SECTION 5.0
5.1

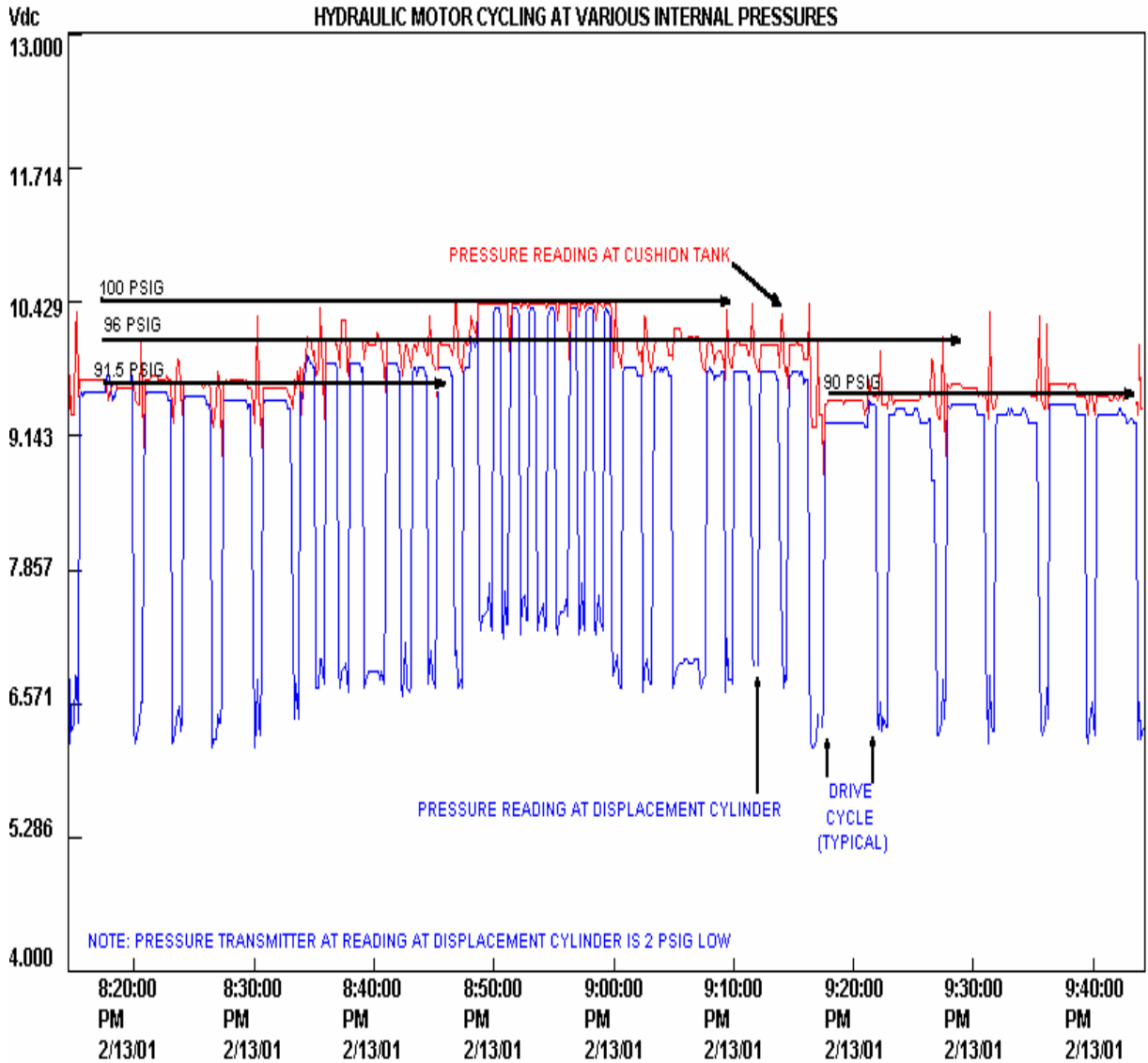

Data extracted from motor as per exact layout of drawing 12 in patent application document. Page 15 of booklet "SCIENTIFIC/TECHNICAL OBSERVATIONS AND OPINIONS" illustrates this circuit.

VOLUME RELATIONSHIP OF A DIAMOND SHAPED PISTON RELATIVE TO A
CONVENTIONAL PISTON FOR THE SAME LINEAR TRAVEL

